

Spotlight for installations on fountain nozzles, completely made in AISI 316L stainless steel



STAINLESS STEEL



IT Apparecchio di illuminazione a LED, interamente realizzato in acciaio inox AISI 316L, con trattamento di passivazione brevetto OXALUM. Grado di protezione IP68 per profondità fino a 5 m. Di forma circolare, diametro 150 x altezza massima di 35 mm, filetto interno da 2", cavo di alimentazione sommersibile di 2,80 m per i modelli a luce fissa e di 14,80 m per la versione RGB. La lunghezza del cavo può essere modificata su richiesta onde evitare giunzioni in zone a rischio di infiltrazione d'acqua. Con 21 Led, modello NCS Nichia nei colori indicati in tabella o in RGB, con alimentazione in tensione 24Vdc per i modelli a singolo colore e con driver 0-24 Vdc per i modelli in RGB. Disponibile con ottiche da 15°, 25°, 40° e 120°. Per l'illuminazione di accento in fontane, attrazioni d'acqua ecc.

EN LED lighting device, completely realized in AISI 316L stainless steel, with OXALUM-patented passivation treatment. Protection degree IP68 for depths up to 5 m. Round, diameter 150 mm x a maximum height of 35 mm, internal thread 2", submersible supply cable, with length of 2,80 m for fixed light models and of 14,80 m for the RGB version. The cable length can be modified on demand, in order to avoid junctions in areas where there is risk of water penetration. NCS Nichia model with 21 LEDs, available in the colours listed in the table or in the RGB version, with power supply at 24Vdc for the single-colour models and with driver 0-24Vdc for the RGB models. Available with lenses of 15°, 25°, 40° and 120°. For emphatic lighting of fountains, water attractions, etc.

FR Appareil d'illumination à LED, complètement fabriqué en acier inoxydable AISI 316L, avec traitement de passivation breveté par OXALUM. Degré de protection IP68 pour profondeurs jusqu'à 5 m. De forme circulaire, diamètre 150 mm x hauteur maximale 35 mm, filetage interne 2", câble d'alimentation submersible de 2,80 m pour les modèles à lumière fixe et de 14,80 m pour la version RGB. La longueur du câble peut être modifiée sur demande pour éviter jonctions en lieux où il y a le risque de pénétration d'eau. Avec 21 LEDs, modèle NCS Nichia, dans les couleurs indiquées dans la table avec alimentation 24Vdc pour les modèles avec une seule couleur et dans la version RGB alimentation parmi driver 0-24Vdc. Disponible avec optiques de 15°, 25°, 40° et 120°. Pour une illumination emphatique des fontaines, jeux d'eau, etc.

DE LED-Beleuchtungsgerät aus rostfreiem AISI 316L Stahl, mit passiver Oxydationsbehandlung (OXALUMs Patent). Schutzart IP68 für Tiefe bis zu 5 m. Rund, Durchmesser 150 mm x maximale Höhe 35 mm; Unterwasserversorgungskabel: 2,80 m lang für die Festlichtmodelle und 14,80 m lang für die RGB-Version. Die Länge des Kabels kann auf Anfrage modifiziert werden, um Verbindungen zu vermeiden, wo es Risiko von Wasserpenetration besteht. Mit 21 LEDs, NCS Nichia-Modelle, verfügbar in den in der Tabelle gezeigten Farben, mit 24Vdc Versorgung für die Modelle einer einzigen Farbe. Für die RGB-Version Versorgung durch ein 0-24Vdc Driver. Verfügbar mit Optiken von 15°, 25°, 40° und 120°. Für eine emphatische Beleuchtung von Springbrunnen, Wasserspielen, usw.

Article (lens 15°)	Article (lens 25°)	Article (lens 40°)	Article (no lens 120°)	Light source	Light colour	Wattage	Tension
ATL21300	ATL21700	ATL21600	ATL21800	21 W POW-LED warm white	3000K	21W 3360 lumen	24Vdc Brown+ / Blue-
ATL21301	ATL21701	ATL21601	ATL21801	21 W POW-LED cold white	5700K	21W 4200 lumen	24Vdc Brown+ / Blue-
ATL21305	ATL21705	ATL21605	ATL21805	21 W POW-LED natural white	4000K	21W 3360 lumen	24Vdc Brown+ / Blue-
ATL21RGB/15	ATL21RGB/25	ATL21RGB/40	ATL21RGB/SL	21 W POW-LED RGB		21W 1785 lm	24Vdc with driver

Power supply	Tension
LXP35/24	Ideal for the power supply of any article of the series ATLANTICUS in the warm white, cold white and natural white versions
DDL1/21H	For the power supply of 1 to 5 articles of the series ATLANTICUS RGB

For plants envisaging the use of numerous articles, contact our technical office to know the codes of the power supplies.

IT INSTALLAZIONE: Atlanticus è adatto per essere avvitato su ugelli mediante filetto da 2" (vedere esempio foto 1). Per ugelli più piccoli sono disponibili accessori per ridurre il diametro interno del filetto da 2" a 1"-1/2 o da 2" a 1".

EN INSTALLATION: Atlanticus is suitable for being screwed around nozzles through a thread of 2" (see example photo 1). For smaller nozzles, accessories made to reduce the internal diameter of the thread from 2" to 1"-1/2 or from 2" to 1" are also available.

FR INSTALLATION: Atlanticus est idéal pour être vissé sur les ajutages à l'aide d'un filetage de 2" (voir exemple photo 1). Pour les ajutages plus petits, des accessoires sont disponibles pour réduire le diamètre interne du filetage de 2" à 1" -1/2 ou de 2" à 1".

DE INSTALLATION: Atlanticus ist geeignet mit einem 2" Gewinde auf Düsen aufgeschraubt zu werden (sehen Sie Beispielfoto 1). Für kleinere Düsen ist ein Zubehör erhältlich, um den Gewindeinnendurchmesser von 2" auf 1" -1/2 oder von 2" auf 1" zu reduzieren.

FOTO 1 - PHOTO 1



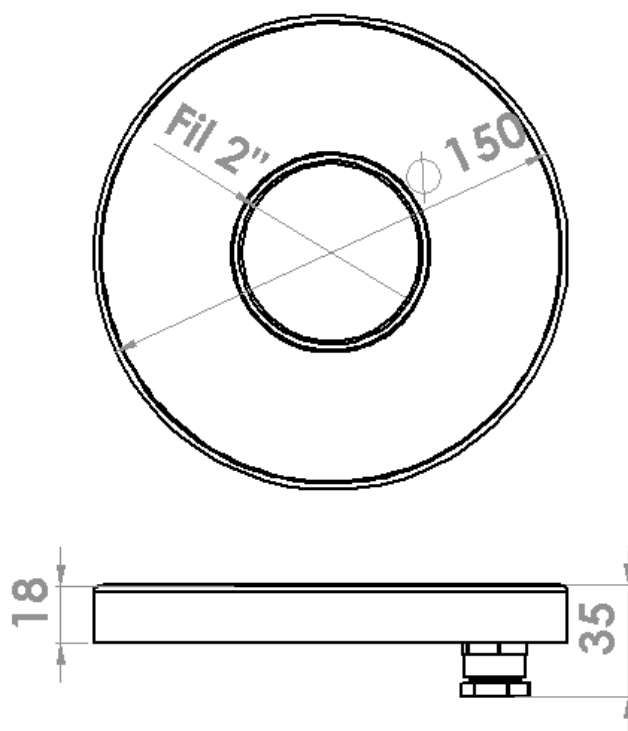

Accessories	Description
MAN.ATL2"/1"	Atlanticus's sleeve with thread reduction from 2" to 1"
MAN.ATL2/1-1/2	Atlanticus's sleeve with thread reduction from 2" to 1"1/2



